

S Series Gearbox

■ Model Name

S-060-010-17608

Series S	Body Size 040 ... 40mm 060 ... 60mm 090 ... 90mm	Ratio 003 ... 3:1 ~ 100 ... 100:1	Motor Mount 17608 ... CM1-X-23XXX ~ 17610 ... CM2-X-56BXX
-------------	---	--	--

■ S-060 in-line planetary gearbox Dimensions (UNIT:mm [inch])

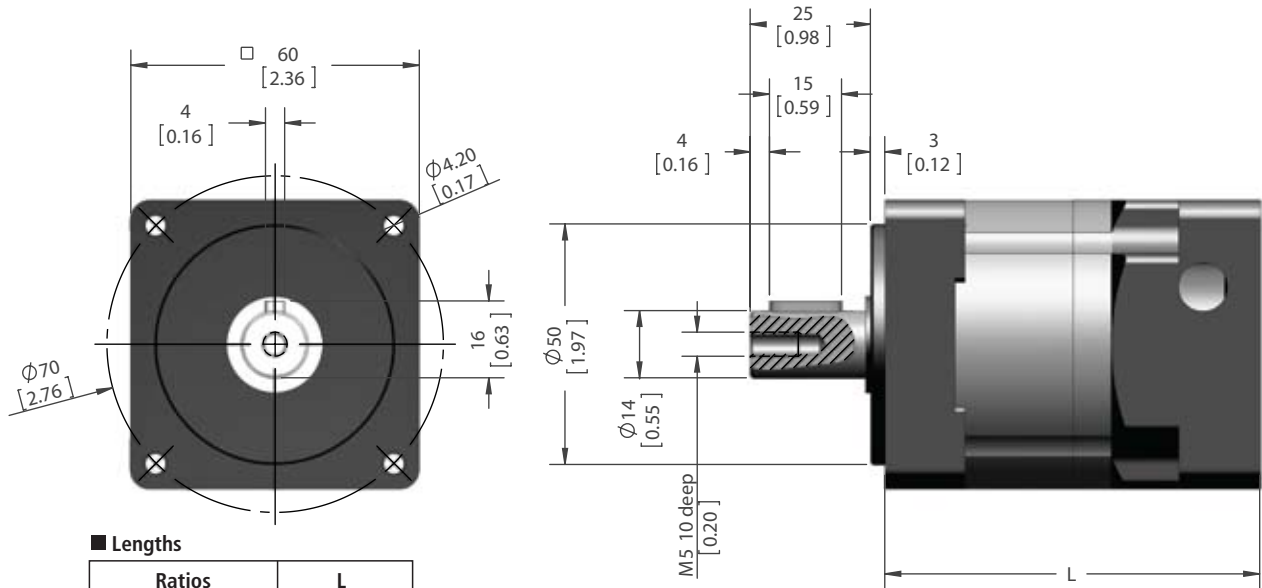

■ Lengths

Ratios	L
3:1 to 10:1 Ratios	78 [3.07]
12:1 to 100:1 Ratios	102 [4.01]

■ Flange Options

Cool Muscle Model	Input Flange
CM1-X-23XXX	-17608
CM2-X-56BXX	-17610
CM2-X-60A10A	-01910
CM2-X-60A40A	-01917
RAAS/RLAS-060	-RAAS60

■ Operational Specifications

S-060 Model	
Radial Load	500N
Axial Load	600N
Torsional Stiffness	3Nm/arcmin
Service Life	10000hrs
Weight	1Kg/1.5kg



Gearbox Performance

All gearboxes are pre-matched for Cool Muscle servos. Torque and speed output specifications are dependant on the matched motor. The S Series gearbox operates at a 95% efficiency rating for the single stage model and 90% for the double stage model. These values can be used to calculate the final torque output of the combined motor + gearbox combination. Gearbox backlash is measured at 6arc/min for single stage units and 10 arc/min for double stage units.

40mm, 60mm, and 90mm frame sizes are available to fit NEMA 17 to 34 or 40mm to 90mm motor frame sizes. CAD files with full dimensions for each size are available at www.coolmuscle.com



For ratios of 20:1 or greater, please use the S-090 size gearbox with the CM2-C-60A40A 400W servo.